

AISC Live Webinars

Thank you for joining our live webinar today.
We will begin shortly. Please standby.

Thank you.

Need Help?
Call ReadyTalk Support: 800.843.9166

Design of Curved Members

Part 1: Design of Vertically-Curved Members
December 5, 2019



AISC Live Webinars

Today's live webinar will begin shortly. Please stand by.

As a reminder, all lines have been muted. Please type any questions or comments through the chat feature on the left portion of your screen.

Today's audio will be broadcast through the internet.
Alternatively, to hear the audio through the phone, dial:

(866)-519-2796
Passcode: 418875



AISC Live Webinars

Audio Options

Today's audio will be broadcast through the internet.

Alternatively, to hear the audio through the phone, dial:

(866)-519-2796
Passcode: 418875



AISC Live Webinars

AIA Credit

AISC is a Registered Provider with The American Institute of Architects Continuing Education Systems (AIA/CES). Credit(s) earned on completion of this program will be reported to AIA/CES for AIA members. Certificates of Completion for both AIA members and non-AIA members are available upon request.

This program is registered with AIA/CES for continuing professional education. As such, it does not include content that may be deemed or construed to be an approval or endorsement by the AIA of any material of construction or any method or manner of handling, using, distributing, or dealing in any material or product.

Questions related to specific materials, methods, and services will be addressed at the conclusion of this presentation.



AISC Live Webinars

Copyright Materials

This presentation is protected by US and International Copyright laws. Reproduction, distribution, display and use of the presentation without written permission of AISC is prohibited.

© The American Institute of Steel Construction 2019

The information presented herein is based on recognized engineering principles and is for general information only. While it is believed to be accurate, this information should not be applied to any specific application without competent professional examination and verification by a licensed professional engineer. Anyone making use of this information assumes all liability arising from such use.



AISC Live Webinars

Course Description

Design of Vertically-Curved Members
December 5, 2019

While curved members can be both structurally efficient and aesthetically interesting, their behavior can be much different than their straight counterparts. This two-part webinar series, presented by the author of AISC Design Guide 33 – Curved Member Design, provides guidance on how to use the AISC Specification to design curved members. This 'equivalent straight member' approach allows the use of existing commercial software for curved member design by modifying effective length factors and lateral-torsional buckling modification factors to account for the curvature. This course will provide a brief overview of the design guide and detailed design information on both vertically- and horizontally-curved members.

This session will review the design of vertically-curved members for axial, flexural, and combined loading. A special buckling limit state, unique to vertically-curved members, will be introduced. Finally, the concepts will be illustrated with a design example.



AISC Live Webinars

Learning Objectives

- Identify the phenomenon of snap-through buckling, and how it can be avoided through arch geometry.
- Describe how in-plane flexural buckling is influenced by end conditions and the geometrical form of an arch.
- Explain how to calculate effective length factors that allow one to design vertically-curved members for axial forces buckling out-of-plane, using code provisions written for straight members.
- Explain how to calculate modification factors that allow one to design vertically-curved members for lateral-torsional buckling, using code provisions written for straight members.



Design of Curved Members

Part 1: Design of Vertically-Curved Members
December 5, 2019



Bo Dowswell, PE, PhD
ARC International, LLC
Birmingham, AL



Course Outline

- Session 1 (December 5)
 - Introduction
 - Overview of Design Guide 33
 - Design of vertically-curved members
- Session 2 (December 12)
 - Design of horizontally-curved members



9

General Information on Curved Members

Introduction



Introduction

Vertically-Curved Members



Photographs courtesy of the AISC Bender/Roller Committee



11

Introduction

Horizontally-Curved Members

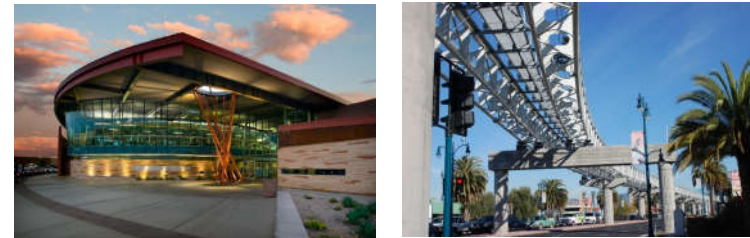

Photographs courtesy of the AISC Bender/Roller Committee



12

General Information on Curved Members

Overview of Design Guide 33



Design Guide Overview

Purpose of Design Guide 33

- Design guidance
 - Vertically-curved members
 - Horizontally-curved members
 - Connections



14

Design Guide Overview

- Practical information
 - Fabrication
 - Detailing

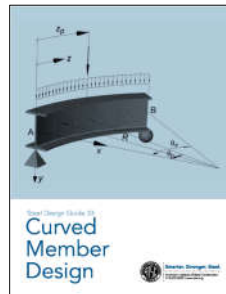

15

Design Guide Overview

Contents of Design Guide 33

- Chapter 1: Introduction
 - Typical applications of curved members
- Chapter 2: Curving Steel Members
 - Bending geometries and processes



16

Design Guide Overview

Contents of Design Guide 33

- Chapter 3: Design for Bending
 - Preventing fracture and distortion during the bending operation
- Chapter 4: Fabrication and Detailing
 - Tolerances, fabrication and detailing



17

Design Guide Overview

- Chapter 5: General Design Issues
 - Material properties, contract documents, etc.
- Chapter 6: Vertically-Curved Members
- Chapter 7: Horizontally-Curved Members



18

Design Guide Overview

- Chapter 8: Design Examples
- Glossary
- List of bender-roller companies



19

Vertically-Curved Members

Session Description



Session Description

- Axial strength
- Flexural strength
- Combined loads
- Design Example



21

Vertically-Curved Members

Axial Strength



Axial Strength

Arches

- Structurally efficient
- Loads carried primarily by compression



Photograph courtesy of the AISC Bender/Roller Committee



23

Axial Strength

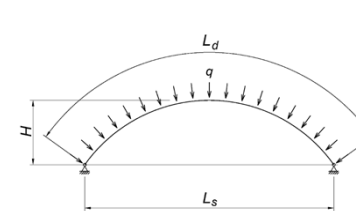

Circular

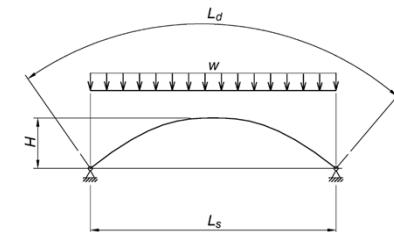

Parabolic



24

Vertically-Curved Members

Axial Strength

In-Plane Strength



In-Plane Strength

- Curved Members \neq Straight Members
- Buckled Shape

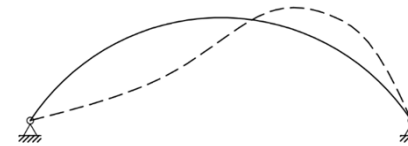

26

In-Plane Strength

- Support spreading
 - Increases deflection
 - Can lead to collapse

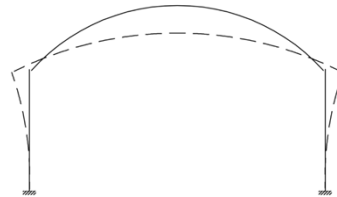

27

In-Plane Strength

- Horizontal restraints

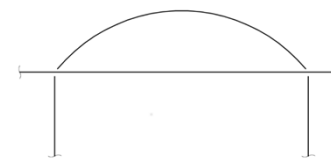

Tension Tie

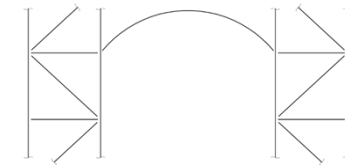

Vertical Truss



28

In-Plane Strength

Snap-Through Buckling

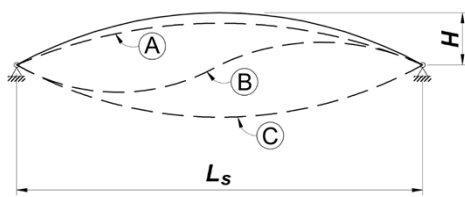

A: Deflected shape
 B: Antisymmetric mode
 C: Symmetric mode



29

In-Plane Strength

Snap-Through Buckling

- Sensitive to second-order effects
- Sensitive to support spreading
- Difficult to predict





30

In-Plane Strength

Snap-Through Buckling

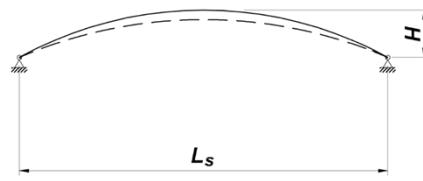
- Generally, not critical for arches with:
 - Rigid supports
 - $H/L_s > 0.2$





31

In-Plane Strength

Snap-Through Buckling

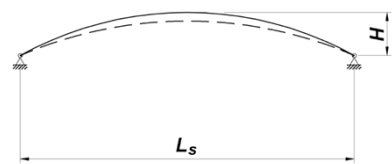
- When $H/L_s \leq 0.2$, L_s/r_i must exceed $(L_s/r_i)_{crit}$



r_i = in-plane radius of gyration



32

In-Plane Strength

		$(L_s/r_i)_{crit}$		
		H/L_s		
		0.10	0.15	0.20
End Conditions	Pinned	59	36	35
	Fixed	150	71	68



33

In-Plane Strength



- Design as a straight column
- Flexural buckling provisions in AISC *Specification* Section E3



34

In-Plane Strength

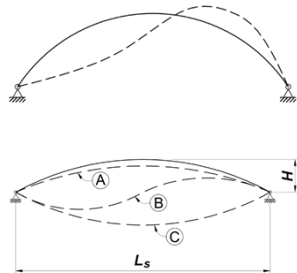

- Applicable only for flexural buckling
- Not valid for snap-through buckling

35

In-Plane Strength

- Unbraced length, $L \rightarrow L_d$

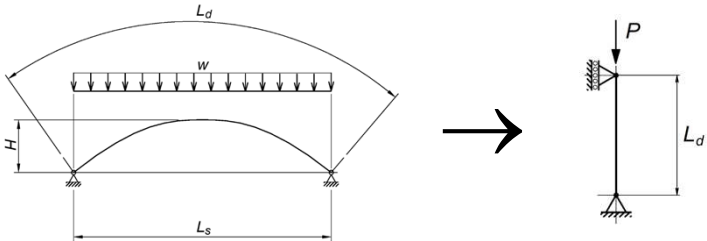



36

In-Plane Strength

- P = maximum axial load in the arch

The diagram illustrates the equivalent column model for an arch. On the left, an arch of height H and span L_s is shown under a uniformly distributed load w . The effective length of the arch is L_d . An arrow points to the right, where an equivalent column of height L_d is shown with a point load P applied at the top, representing the maximum axial load in the arch.



37

In-Plane Strength

In-plane effective length factor, K_i			
Arch Form	End Conditions	H/L_s	K_i
Circular	Pinned	$0.1 \leq H/L_s \leq 0.3$	0.55
		$0.3 \leq H/L_s \leq 0.5$	0.60
	Fixed	All	0.40
Parabolic	Pinned	All	0.50
	Fixed	$0.1 \leq H/L_s < 0.3$	0.40
			$0.3 \leq H/L_s \leq 1.0$



Vertically-Curved Members

Axial Strength

Out-of-Plane Strength



Out-of-Plane Strength

- Buckled shape
 - Translation
 - Twisting

The diagram shows an arch of radius R under a uniformly distributed load w and axial loads P at its ends. The buckled shape is shown with a lateral translation u and a twisting angle ϕ . A cross-section labeled "SECTION" shows the arch's profile and the direction of the load w .



40

Out-of-Plane Strength

- Most arches are braced against out-of-plane translation
- Each segment can buckle between brace points

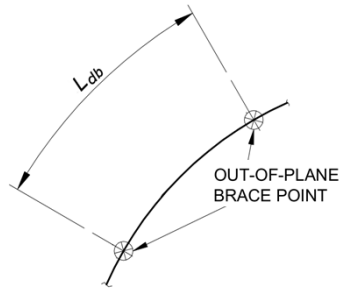

41

Out-of-Plane Strength

- Design as a straight column
- Flexural buckling provisions in AISC *Specification* Section E3



42

Out-of-Plane Strength

- Unbraced length, $L \rightarrow L_{db}$

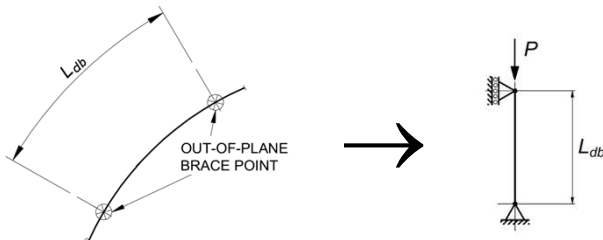

43

Out-of-Plane Strength

- P = maximum load in the segment

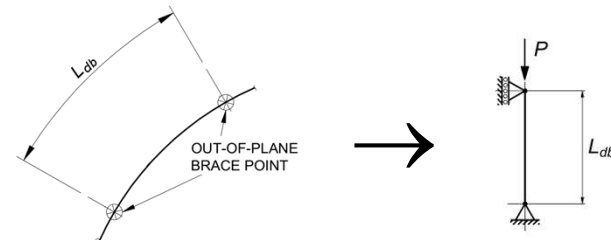

44

Out-of-Plane Strength

- Flexural-torsional buckling → flexural buckling

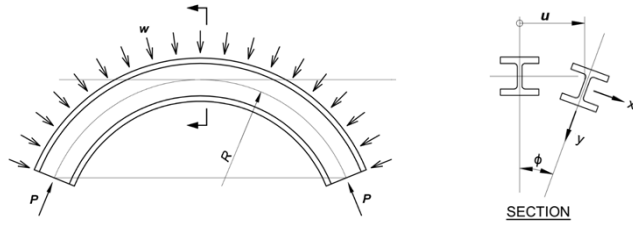

45

Out-of-Plane Strength

- Effective length factor, K_o : Circular doubly-symmetric segments

$$K_o = \frac{\sqrt{1 + \frac{1}{C_o} \left(\frac{\theta_b}{\pi}\right)^2}}{1 - \left(\frac{\theta_b}{\pi}\right)^2}$$



46

Out-of-Plane Strength

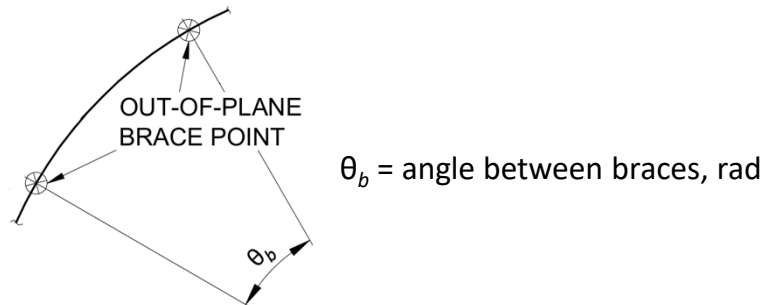

47

Out-of-Plane Strength

$$C_o = \frac{1}{I_o} \left[\frac{GJ}{E} + C_w \left(\frac{\pi}{L_{db}} \right)^2 \right]$$

C_w = warping constant

J = torsional constant

I_o = moment of inertia \perp to the axis of curvature



48

Vertically-Curved Members

Flexural Strength



Flexural Strength

- Buckled shape
 - Translation
 - Twisting

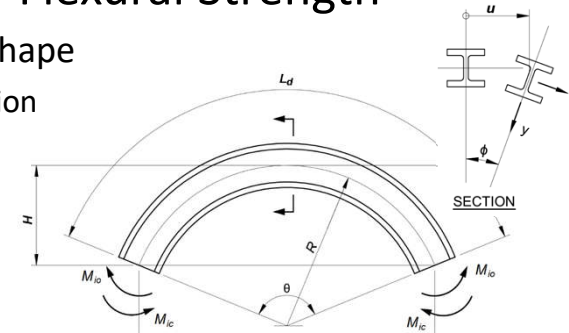

50

Flexural Strength

- Lateral-torsional buckling strength is dependent on the loading direction
 - Opening moment, M_{io}
 - Closing moment, M_{ic}

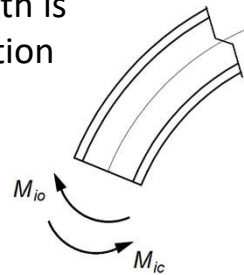

51

Flexural Strength



- Design as a straight beam
- Each unbraced segment is treated independently
- AISC *Specification* Chapter F
- Lateral-torsional buckling modification factor, $C_b \rightarrow C_{bi}$



52

Flexural Strength

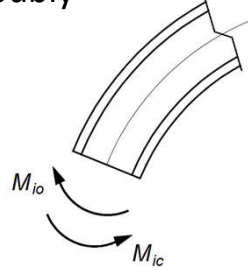

Modification factor, C_{bi} : Circular doubly-symmetric segments

$$C_{bi} = C_{bs} \left(\sqrt{1 + C_a^2 - \frac{C_y C_z}{R^2 M_{es}^2}} \pm C_a \right)$$

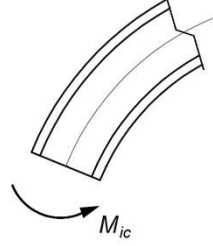

53

Flexural Strength



Closing moments → positive root

$$C_{bi} = C_{bs} \left(\sqrt{1 + C_a^2 - \frac{C_y C_z}{R^2 M_{es}^2}} + C_a \right)$$

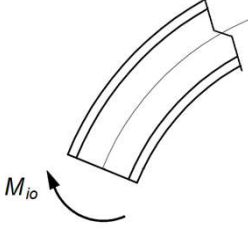

54

Flexural Strength

Opening moments → negative root

$$C_{bi} = C_{bs} \left(\sqrt{1 + C_a^2 - \frac{C_y C_z}{R^2 M_{es}^2}} - C_a \right)$$



55

Flexural Strength

$C_{bs} = C_b$ for an equivalent straight member (AISC Specification Equation F1-1)

$$C_b = \frac{12.5M_{max}}{2.5M_{max} + 3M_A + 4M_B + 3M_C}$$

M_{max} = absolute value of max. moment in the segment
 $M_{A,B,C}$ = absolute value of moment at $\frac{1}{4}$, $\frac{1}{2}$, $\frac{3}{4}$ points



56

Flexural Strength

M_{es} = elastic lateral-torsional buckling moment of the equivalent straight member subjected to uniform moment with a length equal to L_{db}

$$M_{es} = \frac{\pi}{L_{db}} \sqrt{EI_o GJ + \left(\frac{\pi E}{L_{db}}\right)^2 I_o C_w}$$



57

Flexural Strength

L_{db} = developed length between points that are either braced against lateral displacement of the compression flange or twisting of the cross section

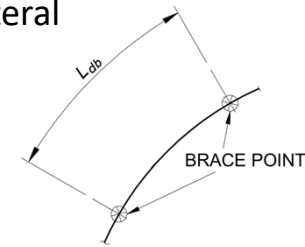

58

Flexural Strength

$$C_a = \frac{C_y + C_z}{2RM_{es}}$$

$$C_y = EI_o$$

$$C_z = GJ + \frac{\pi^2 EC_w}{L_{db}^2}$$



Vertically-Curved Members

Combined Loads



Combined Loads

Axial-Flexure Interaction

- AISC *Specification* Section H1 for doubly-symmetric members



61

Combined Loads

Axial-Flexure Interaction

- When $P_r/P_c \geq 0.2$

$$\frac{P_r}{P_c} + \frac{8}{9} \left(\frac{M_r}{M_c} \right) \leq 1.0$$

P_r M_r = required strengths P_c M_c = available strengths



62

Combined Loads

Axial-Flexure Interaction

- Strength must be verified at each segment
- Use the minimum P_r/P_c ratio for each segment

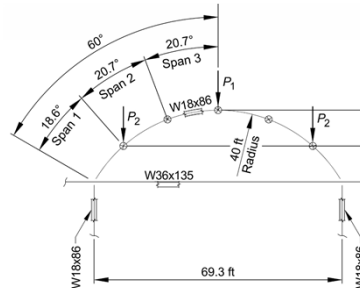

63

Combined Loads

Axial-Flexure Interaction

- In-plane buckling: P_r/P_c is constant for all segments
- Out-of-plane buckling: both P_r and P_c can vary between segments



64

Combined Loads

Second-Order Effects

- Amplified first-order moment: $M_{ri} = B_i M_{i1}$
- Second-order analysis (Section 6.3.1 of Design Guide 33)

M_{i1} = first-order moment about the axis of curvature



65

Combined Loads

Second-Order Effects

$$B_i = \frac{1}{1 - \alpha \frac{P_r}{P_{ei}}} \quad \begin{array}{l} \alpha = 1.00 \text{ (LRFD)} \\ \alpha = 1.60 \text{ (ASD)} \end{array}$$

P_r = maximum axial load in the arch

P_{ei} = elastic critical load for in-plane buckling



66

Combined Loads

Second-Order Effects

$$P_{ei} = \frac{\pi^2 E I_i}{(K_i L_d)^2}$$

I_i = moment of inertia about the axis of curvature

K_i = effective length factor for in-plane buckling

L_d = developed length of the arch



67

Vertically-Curved Members

Design Example



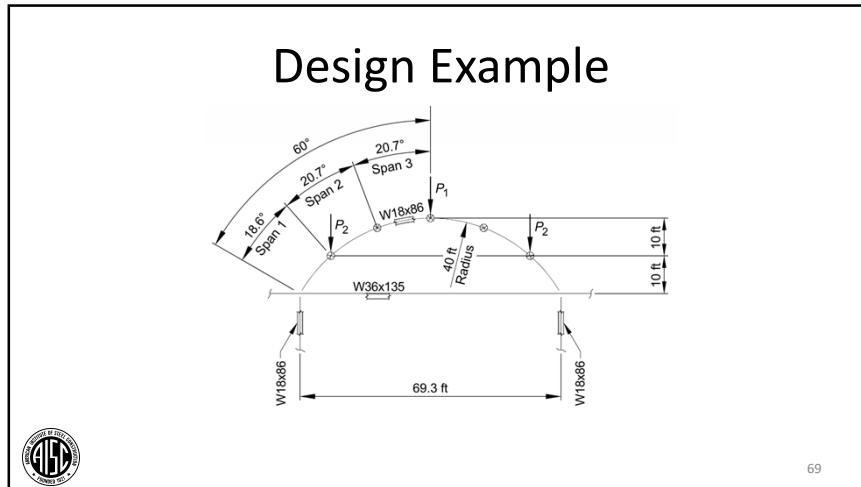

Vertically-Curved Members

Design Example

Problem Statement

Problem Statement

- Verify that the arch is adequate for the imposed loading
- Use LRFD

71

Problem Statement

- Curved member
 - W18×86
 - ASTM A992
 - Bent the hard way
 - Circular curve

72

Problem Statement

- The factored (LRFD) loads are
 - $P_{1u} = 120$ kips
 - $P_{2u} = 75$ kips

The diagram shows a curved beam with three spans: Span 1 (18.6°), Span 2 (20.7°), and Span 3 (20.7°). The beam is supported by a W36x135 column at each end. A W18x86 beam is connected to the top of the W36x135 column. The beam has a 40 ft radius. Factored loads P_1 and P_2 are applied at the top of the W18x86 beam at the spans. P_1 is at the top of Span 3, and P_2 is at the top of Span 2. The loads are circled in red.

73

Problem Statement

- Supports
 - Translation fixed in all directions
 - Rotation free in all directions

The diagram is identical to the previous one, but the supports at the ends of the W36x135 column are circled in red.

74

Problem Statement

- Braces
 - Prevent out-of-plane translation
 - Prevent torsional rotation

The diagram is identical to the previous ones, but braces are shown at the top of the W18x86 beam at the spans. The braces are circled in red.

75

Problem Statement

- Assume Span 3 is critical

The diagram is identical to the previous ones, but Span 3 is circled in red.

76

Vertically-Curved Members

Design Example

Properties



Properties

- Material properties of ASTM A992
(AISC *Manual* Table 2-4)

$$F_y = 50 \text{ ksi}$$

$$F_u = 65 \text{ ksi}$$



78

Properties

- Dimensions of W18×86
(AISC *Manual* Table 1-1)

$$d = 18.4 \text{ in.} \quad t_w = 0.480 \text{ in.}$$

$$b_f = 11.1 \text{ in.} \quad t_f = 0.770 \text{ in.}$$

$$h_o = 17.6 \text{ in.}$$



79

Properties

- Section properties of W18×86
(AISC *Manual* Table 1-1)

$$I_x = 1,530 \text{ in.}^4 \quad S_x = 166 \text{ in.}^3$$

$$r_x = 7.77 \text{ in.} \quad Z_x = 186 \text{ in.}^3$$

$$I_y = 175 \text{ in.}^4 \quad r_y = 2.63 \text{ in.}$$

$$J = 4.10 \text{ in.}^4 \quad C_w = 13,600 \text{ in.}^6$$

$$r_{ts} = 3.05 \text{ in.}$$



80

Vertically-Curved Members

Design Example

Arch Geometry



Arch Geometry

- Centroidal radius
 $R = (40 \text{ ft})(12 \text{ in./ft})$
 $= 480 \text{ in.}$

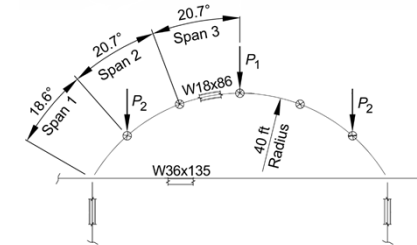

82

Arch Geometry

- Arch angle

$$\theta = (120^\circ) \left(\frac{\pi \text{ rad}}{180^\circ} \right)$$

$$= (2\pi / 3) \text{ rad}$$

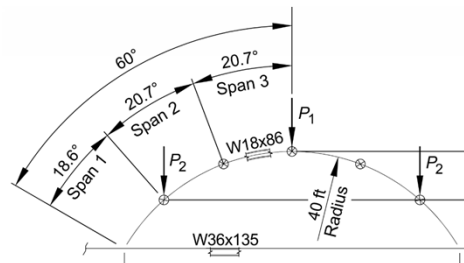

83

Arch Geometry

- Span length (chord)
 $L_s = (69.3 \text{ ft})(12 \text{ in./ft})$
 $= 832 \text{ in.}$

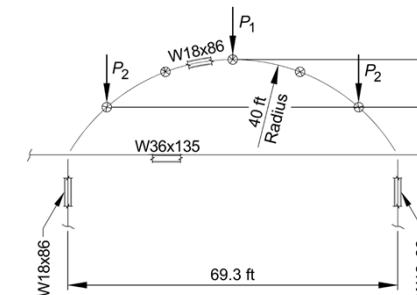

84

Arch Geometry

- Rise

$$H = (20 \text{ ft})(12 \text{ in./ft}) = 240 \text{ in.}$$

85

Arch Geometry

$$\frac{H}{L_s} = \frac{240 \text{ in.}}{832 \text{ in.}} = 0.288$$

86

Arch Geometry

- Developed arc length

$$L_d = (40 \text{ ft})[(2\pi / 3)\text{rad}](12 \text{ in./ft}) = 1,010 \text{ in.}$$

87

Vertically-Curved Members

Design Example

Structural Analysis

Structural Analysis

Finite Element Model

- Segmented spans
 - Straight beam elements
 - $\approx 3^\circ$ arc between nodes
- First-order analysis

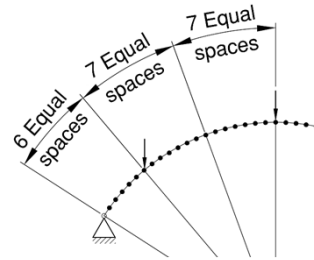

89

Structural Analysis

Deflection

- Maximum @ apex

$$\Delta_1 = 1.07 \text{ in.}$$

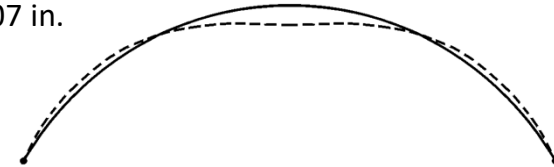

90

Structural Analysis

Deflection

- Design Guide Section 6.3.1:
If Δ_1 is less than $H/40$ (using factored loads for LRFD or 1.6 times the service loads for ASD), a first-order finite element analysis is sufficiently accurate



91

Structural Analysis

Deflection

$$\frac{H}{40} = \frac{240 \text{ in.}}{40} = 6.00 \text{ in.}$$

$$1.07 \text{ in.} < 6.00 \text{ in.} \quad \mathbf{o.k.}$$



92

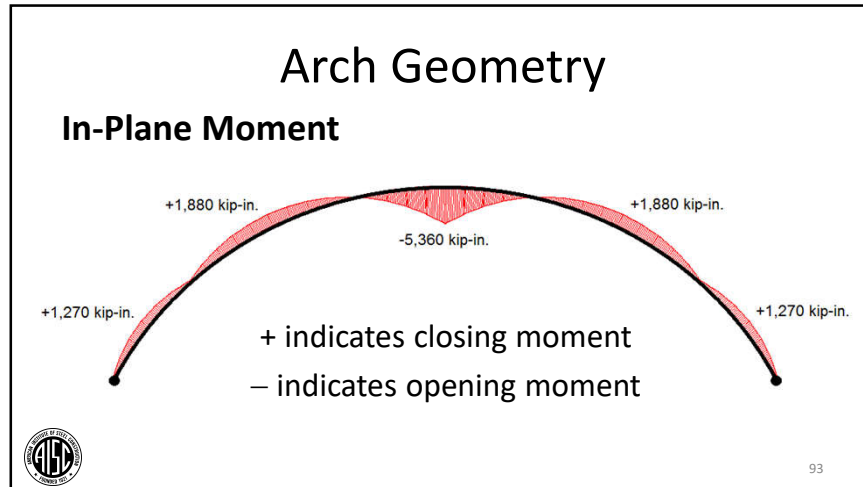

Structural Analysis

Member Loads (kip, in.)			
Location	Axial	Moment	Shear
	P_u	M_{ux}	V_u
Supports	182	0	25.8
Apex	118	–5,360	57.5

94

Structural Analysis

1 st -Order Member Loads (kip, in.)			
Location	Axial	Moment	Shear
	P_u	M_{ux}	V_u
Max./Min. @ Span 3	131	+1,380 –5,360	57.5

95

Vertically-Curved Members

Design Example

Local Buckling

Local Buckling

- Calculations are the same as for a straight member
- Axial: $\lambda_f < \lambda_{rf}$ and $\lambda_w < \lambda_{rw}$ → the W18×86 is non-slender
- Flexure: $\lambda_f < \lambda_{pf}$ and $\lambda_w < \lambda_{pw}$ → the W18×86 is compact



97

Vertically-Curved Members

Design Example

Shear Strength



Shear Strength

- AISC Manual Table 6-2
 $\phi_v V_n = 265 \text{ kips} > V_u = 57.5 \text{ kips}$ **o.k.**



99

Vertically-Curved Members

Design Example

In-Plane Strength



In-Plane Strength

- Snap-through buckling is not critical because:
 - The supports are rigid
 - $H/L_s = 0.288 > 0.2$



101

In-Plane Strength

- AISC *Specification* Section E3
- Radius of gyration about the axis of curvature:
 $r_i = r_x = 7.77$ in.



102

In-Plane Strength

- Unbraced length: $L_d = 1,010$ in.

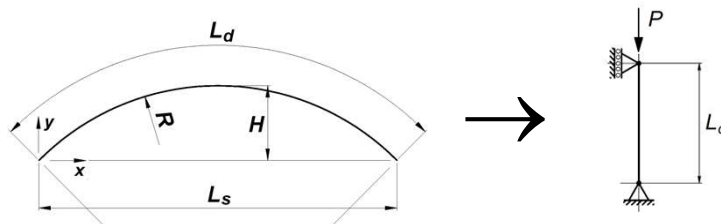

103

In-Plane Strength

- For a circular arch with pinned end conditions and $H/L_s = 0.288$, $K_i = 0.55$

In-plane effective length factor, K_i			
Arch Form	End Conditions	H/L_s	K_i
Circular	Pinned	$0.1 \leq H/L_s \leq 0.3$	0.55
		$0.3 \leq H/L_s \leq 0.5$	0.60
	Fixed	All	0.40



104

In-Plane Strength

$$\begin{aligned}\frac{L_c}{r} &= \frac{K_i L_d}{r_i} \\ &= \frac{(0.55)(1,010 \text{ in.})}{7.77 \text{ in.}} \\ &= 71.5\end{aligned}$$

AISC Manual Table 4-14: $\phi_c F_{cr} = 31.0 \text{ ksi}$



105

In-Plane Strength

- The available strength is

$$\begin{aligned}\phi_c P_{ni} &= (31.0 \text{ ksi})(25.3 \text{ in.}^2) \\ &= 784 \text{ kips}\end{aligned}$$



106

Vertically-Curved Members

Design Example

Out-of-Plane Strength



Out-of-Plane Strength

- AISC Specification Section E3
- Moment of inertia perpendicular to the axis of curvature: $I_o = I_y = 175 \text{ in.}^4$
- Radius of gyration perpendicular to the axis of curvature: $r_o = r_y = 2.63 \text{ in.}$



108

Out-of-Plane Strength

Span 3

$$\theta_b = (20.7^\circ) \left(\frac{\pi \text{ rad}}{180^\circ} \right) = 0.361 \text{ rad}$$

109

Out-of-Plane Strength

$$L_{db} = R\theta_b = (480 \text{ in.})(0.361 \text{ rad}) = 173 \text{ in.}$$

110

Out-of-Plane Strength

- Effective length factor, K_o : Circular doubly-symmetric segments

$$K_o = \frac{\sqrt{1 + \frac{1}{C_o} \left(\frac{\theta_b}{\pi} \right)^2}}{1 - \left(\frac{\theta_b}{\pi} \right)^2}$$

111

Out-of-Plane Strength

$$C_o = \frac{1}{I_o} \left[\frac{GJ}{E} + C_w \left(\frac{\pi}{L_{db}} \right)^2 \right]$$

$$= \frac{1}{175 \text{ in.}^4} \left[\frac{(11,200 \text{ ksi})(4.10 \text{ in.}^4)}{29,000 \text{ ksi}} + (13,600 \text{ in.}^6) \left(\frac{\pi}{173 \text{ in.}} \right)^2 \right]$$

$$= 0.0347$$

112

Out-of-Plane Strength

$$K_o = \frac{\sqrt{1 + \frac{1}{C_o} \left(\frac{\theta_b}{\pi} \right)^2}}{1 - \left(\frac{\theta_b}{\pi} \right)^2} = \frac{\sqrt{1 + \frac{1}{0.0347} \left(\frac{0.361 \text{ rad}}{\pi} \right)^2}}{1 - \left(\frac{0.361 \text{ rad}}{\pi} \right)^2} = 1.19$$



113

Out-of-Plane Strength

$$\begin{aligned} \frac{L_c}{r} &= \frac{K_o L_{db}}{r_o} \\ &= \frac{(1.19)(173 \text{ in.})}{2.63 \text{ in.}} \\ &= 78.3 \end{aligned}$$

AISC Manual Table 4-14: $\phi_c F_{cr} = 28.7 \text{ ksi}$



114

Out-of-Plane Strength

- The available strength is

$$\begin{aligned} \phi_c P_{no} &= (28.7 \text{ ksi})(25.3 \text{ in.}^2) \\ &= 726 \text{ kips} \end{aligned}$$



115

Vertically-Curved Members

Design Example

Second-Order Effects



Second-Order Effects

- Amplified first-order analysis
- Second-order moment: $M_{ux2} = B_i M_{ux}$

$$B_i = \frac{1}{1 - \alpha \frac{P_u}{P_{ei}}}$$

P_{ei} = elastic critical load for in-plane buckling
 $\alpha = 1.00$ (LRFD)



REF: Session 2 Slide 87

117

Second-Order Effects

$$F_e = \frac{\pi^2 E}{\left(\frac{L_c}{r}\right)^2}$$

$$P_{ei} = F_e A_g$$

$$= (56.0 \text{ ksi})(25.3 \text{ in.}^2)$$

$$= 1,420 \text{ kips}$$

$$= \frac{\pi^2 (29,000 \text{ ksi})}{(71.5)^2}$$

$$= 56.0 \text{ ksi}$$



118

Second-Order Effects

$$B_i = \frac{1}{1 - \alpha \frac{P_u}{P_{ei}}} = \frac{1}{1 - (1.0) \left(\frac{182 \text{ kips}}{1,420 \text{ kips}}\right)} = 1.15$$



119

Second-Order Effects

2 nd -Order Moments (kip-in.)	
Location	M_{ux2}
Max./Min. @	+1,590
Span 3	-6,160



120

Vertically-Curved Members

Design Example

Flexural Strength



Flexural Strength

- AISC *Specification* Section F2
- Moment of inertia perpendicular to the axis of curvature: $I_o = I_y = 175 \text{ in.}^4$



122

Flexural Strength

$$\begin{aligned} M_p &= F_y Z_x \\ &= (50 \text{ ksi})(186 \text{ in.}^3) \\ &= 9,300 \text{ kip-in.} \end{aligned}$$



123

Flexural Strength

Span 3

$$L_{db} = 173 \text{ in.}$$

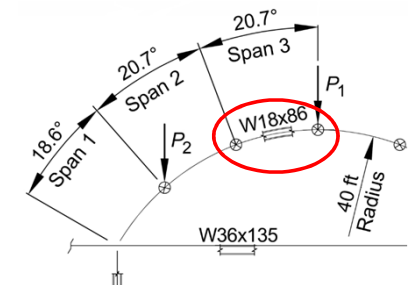

124

Flexural Strength

M_{es} = elastic lateral-torsional buckling moment of the equivalent straight member subjected to uniform moment with a length equal to L_{db}

$$M_{es} = \frac{\pi}{L_{db}} \sqrt{EI_o GJ + \left(\frac{\pi E}{L_{db}}\right)^2 I_o C_w} = 17,200 \text{ kip-in.}$$



125

Flexural Strength

$$\begin{aligned} C_y &= EI_o \\ &= (29,000 \text{ ksi})(175 \text{ in.}^4) \\ &= 5,080,000 \text{ kip-in.}^2 \end{aligned}$$



126

Flexural Strength

$$\begin{aligned} C_z &= GJ + \frac{\pi^2 EC_w}{L_{db}^2} \\ &= (11,200 \text{ ksi})(4.10 \text{ in.}^4) + \frac{\pi^2 (29,000 \text{ ksi})(13,600 \text{ in.}^6)}{(173 \text{ in.})^2} \\ &= 176,000 \text{ kip-in.}^2 \end{aligned}$$



127

Flexural Strength

$$\begin{aligned} C_a &= \frac{C_y + C_z}{2RM_{es}} \\ &= \frac{5,080,000 \text{ kip-in.}^2 + 176,000 \text{ kip-in.}^2}{(2)(480 \text{ in.})(17,200 \text{ kip-in.})} \\ &= 0.318 \end{aligned}$$



128

Flexural Strength

- Span 3





$$C_{bs} = \frac{12.5M_{max}}{2.5M_{max} + 3M_A + 4M_B + 3M_C} = 2.38$$

129

Flexural Strength

Opening moments → negative root

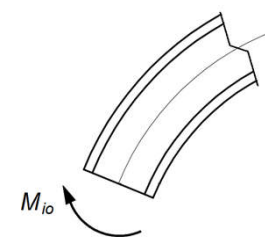
$$C_{bi} = C_{bs} \left(\sqrt{1 + C_a^2 - \frac{C_y C_z}{R^2 M_{es}^2}} - C_a \right)$$

$$= 1.75$$



130

Flexural Strength

- AISC Specification Section F2
 - $L_b = L_{db} = 173 \text{ in.} = 14.4 \text{ ft}$
 - $C_b = C_{bi} = 1.75$
- AISC Manual Table 3-6
 - $L_p = 9.29 \text{ ft}$
 - $L_r = 28.6 \text{ ft}$



131

Flexural Strength

- $L_p < L_b < L_r \rightarrow$ Use AISC Spec. Eq. F2-2

$$M_n = C_b \left[M_p - (M_p - 0.7F_y S_x) \left(\frac{L_b - L_p}{L_r - L_p} \right) \right] \leq M_p$$

$$= 14,700 \text{ kip-in.} > 9,300 \text{ kip-in.}$$

132

Flexural Strength

- The available strength is

$$\begin{aligned}\phi_b M_n &= 0.90(9,300 \text{ kip-in.}) \\ &= 8,370 \text{ kip-in.}\end{aligned}$$



133

Vertically-Curved Members

Design Example

Combined Loading



Combined Loading

- AISC *Specification* Section H1
- In-plane buckling
- Out-of-plane buckling



135

Combined Loading

In-Plane Buckling

- The largest flexural load ratio is at the apex
- The largest axial load ratio is at the supports

$$\frac{P_u}{\phi_c P_{ni}} = \frac{182 \text{ kips}}{784 \text{ kips}} = 0.232$$



136

Combined Loading

$0.232 > 0.2 \rightarrow$ AISC *Specification* Equation H1-1a

$$\frac{P_u}{\phi_c P_{ni}} + \frac{8}{9} \left(\frac{M_u}{\phi_b M_n} \right) \leq 1.0$$

$$0.232 + \left(\frac{8}{9} \right) \left(\frac{6,160 \text{ kip-in.}}{8,370 \text{ kip-in.}} \right) \leq 1.0$$

$0.886 < 1.0$ **o.k.**



137

Combined Loading

Out-of-Plane Buckling (Span 3)

- Largest flexural load in the span
- Largest axial load in the span

$$\frac{P_u}{\phi_c P_{no}} = \frac{131 \text{ kips}}{726 \text{ kips}} = 0.180$$



138

Combined Loading

$0.180 < 0.2 \rightarrow$ AISC *Specification* Equation H1-1b

$$\frac{P_u}{2\phi_c P_{no}} + \frac{M_u}{\phi_b M_n} \leq 1.0$$

$$\frac{0.180}{2} + \frac{6,160 \text{ kip-in.}}{8,370 \text{ kip-in.}} \leq 1.0$$

$0.826 < 1.0$ **o.k.**



139

Combined Loading

Design Summary

- The W18×86 is adequate
- See Design Guide Example 8.1 for further calculations
 - Local strength
 - Connections



140

Conclusions

Vertically-Curved Members

- Design as an equivalent straight member
- Subjected to both axial and flexural loads
- Axial strength is calculated with K_i and K_o
- Flexural strength is calculated with C_{bi}



141

Question time



AISC | Questions?



CEU / PDH Certificates

- You will receive an email on how to report attendance from: registration@aisc.org.
- Be on the lookout: Check your spam filter! Check your junk folder!
- Completely fill out online form. Don't forget to check the boxes next to each attendee's name!



CEU / PDH Certificates

- Reporting site (URL will be provided in the forthcoming email).
- Username: Same as AISC website username.
- Password: Same as AISC website password.

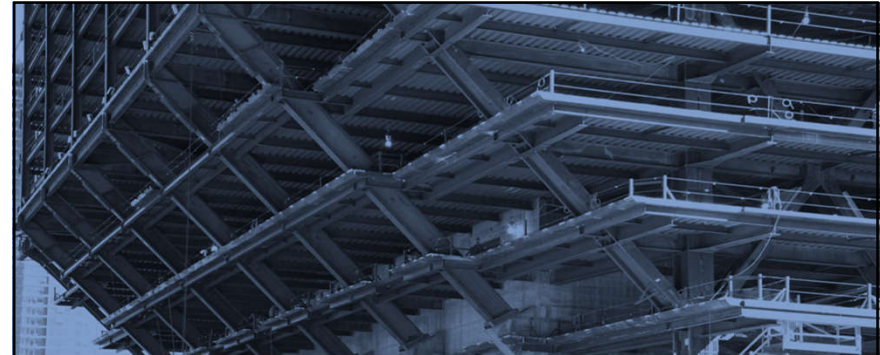

AISC | Thank you

